

P:REACT

LIQUID STATE POLYCONDENSATION

PET in –
future out.





PET Improvement (PET)

The **P:REACT** is the next dimension of PET recycling. It only takes a few minutes to take PET from industrial waste or post-consumer PET and turn it into high-quality rPET.

In contrast to conventional methods, the Liquid State Polycondensation (LSP) method that NGR developed and patented specifically for the **P:REACT** makes it possible to feed a wide range of materials in varying mixture ratios. This technology also features completely controllable iV values and consistently high output quality. This means that the **P:REACT** provides the ideal conditions for connecting to downstream production while also optimizing your ongoing costs.



PET in – future out

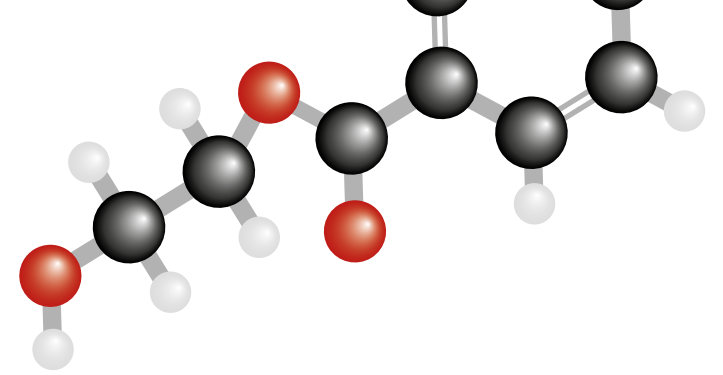

The **P:REACT** revolutionizes the process of PET recycling from the ground up. Thanks to the **Liquid State Polycondensation** (LSP) method developed by NGR, it only takes a short time to process PET waste or flakes to create high-quality rPET. iV values that can be achieved quickly and controlled completely guarantee that the quality of the end product remains consistently high. Absolute process stability and significantly increased energy efficiency also help to maximize the profitability of the system.

THE WORKING PRINCIPLE

The Liquid State Polycondensation method makes use of PET's inherent tendency to condense under vacuum in the melt phase. This condensation results in an extremely quick increase in the iV value. The heavy-duty vacuum decontaminates the material by removing harmful chemicals, which ensures that the material can be used downline for 100% food-safe applications.

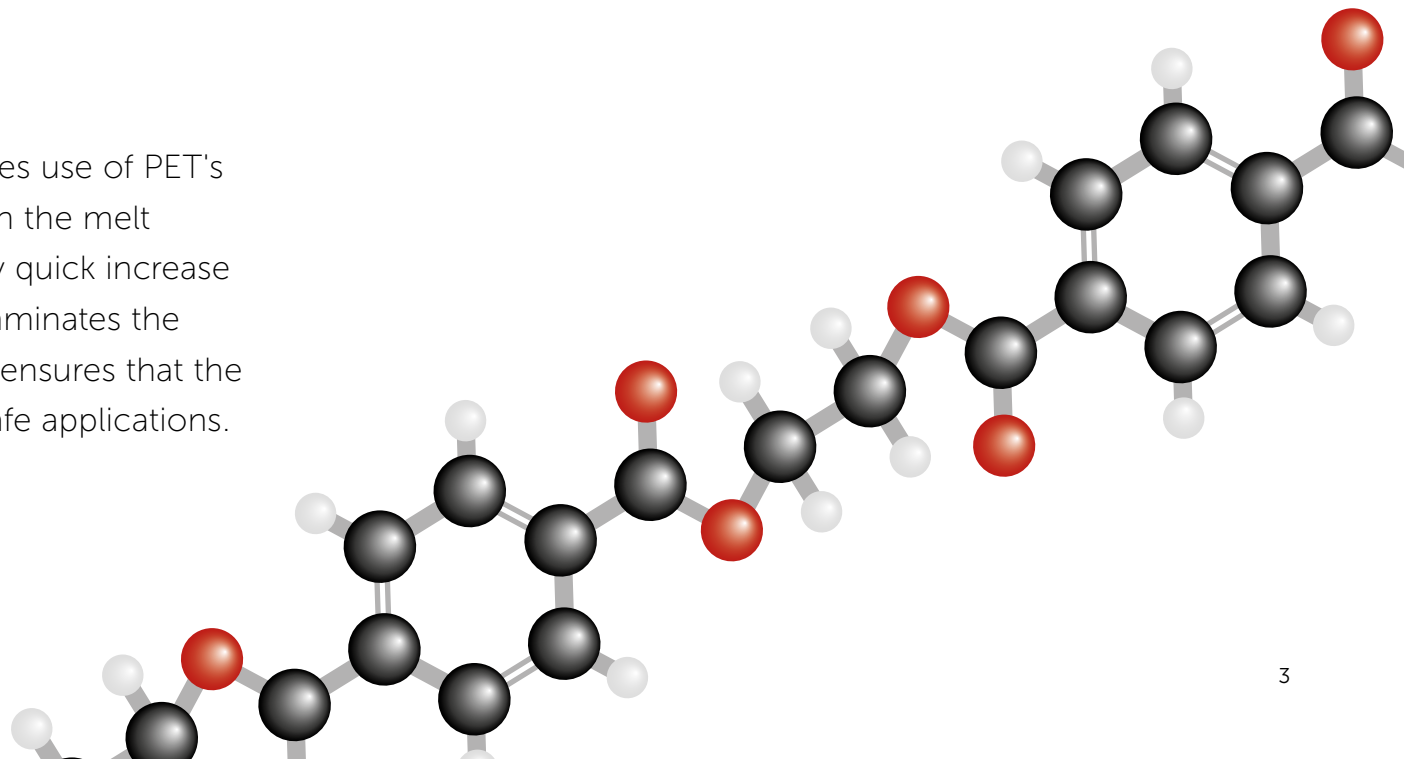

The process steps, a stable quality level

FEEDING

An extremely wide range of PET materials and material shapes are fed into the system. Materials including bottle flakes, punch scrap or even PET fibers are all equally suitable. What's more, the LSP method offsets fluctuations in mixture ratios of the fed materials, opening the door for flexible cost structuring depending on material availability.

EXTRUSION

The **P:REACT** is compatible with all types of extrusion solutions that may be required.

DECONTAMINATION

When the melt enters the decontamination stage, it is shaped into strands and freed of all impurities using a heavy-duty vacuum. The result is that spinning oils are largely removed, for example, from fibers that are being processed.

PELLETIZATION OR DOWNSTREAM PRODUCTION

Downline of the **P:REACT**, the PET melt can be processed to create rPellets. It is also possible to connect the system directly to downstream production of films, fibers, strapping or preforms without any problems.

The process steps, perfect solutions for any application case

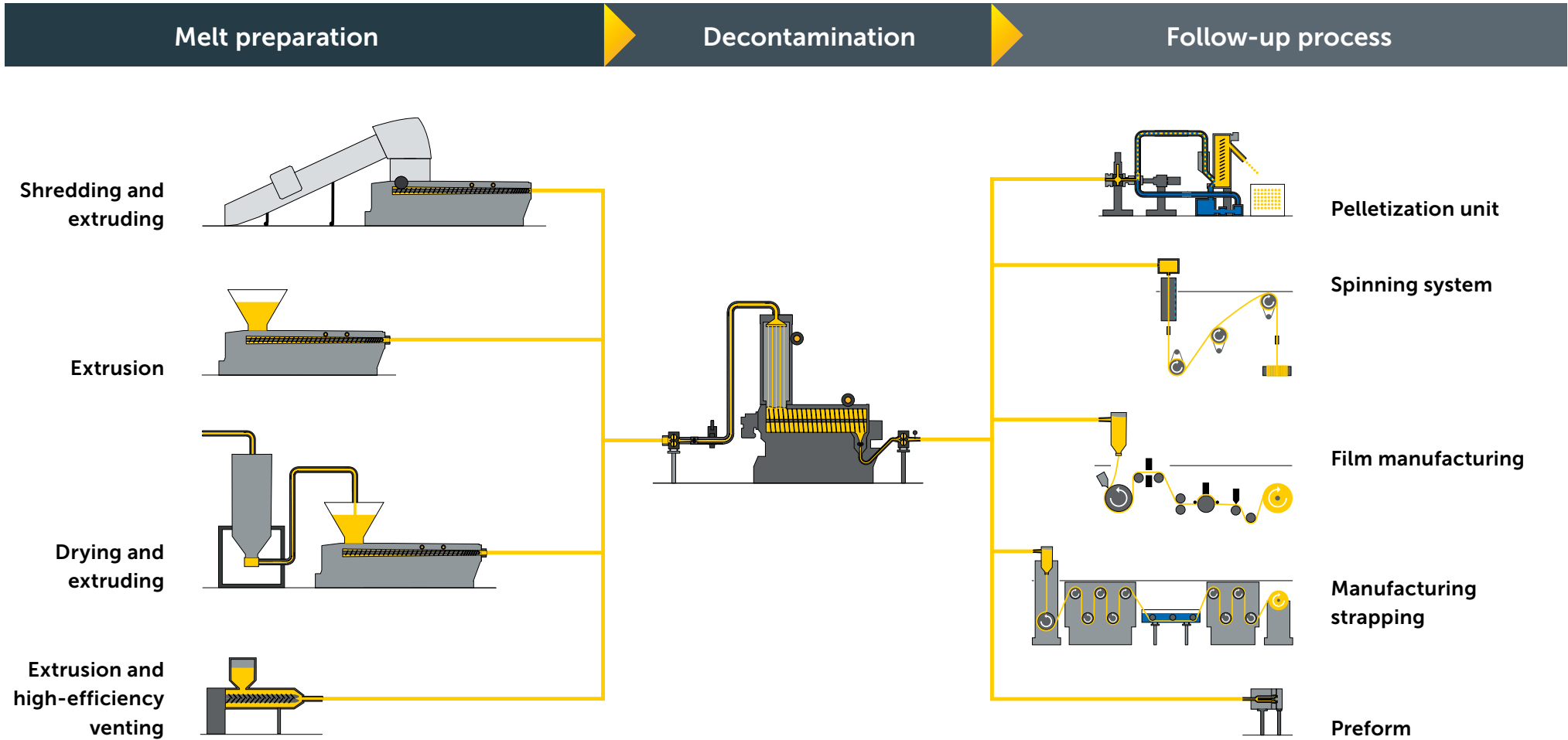

P:REACT At a glance

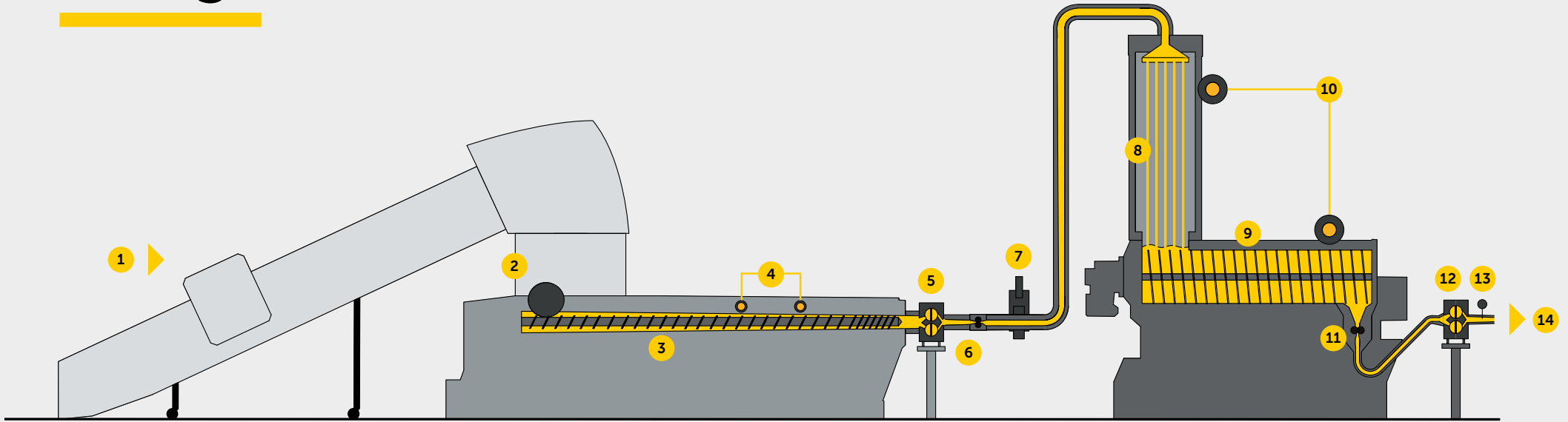

- 1) Manual and/or automatic material feed
- 2) Efficient size reduction (optional)
- 3) Plasticizing
- 4) Effective venting
- 5) Filtration
- 6) Melt pump
- 7) Gate

- 8) High-efficiency vacuum container (melt reactor)
- 9) Horizontal drum
- 10) Discharge of decontaminated substances
- 11) Melt discharge pump
- 12) Filtration
- 13) Ongoing viscosity measurement
- 14) Transfer into downstream production

"Decontamination in the liquid phase is a one-of-a-kind process. On the one hand, the users have extensive control over the desired iV values—and this all is largely independent on the respective input materials. At the same time, we manage to clean the material reliably and within a short period of time."

Bernhard Pichler / Test Center Manager



High-performance, one-of-a-kind decontamination

ONE-OF-A-KIND DECONTAMINATION IN THE LIQUID PHASE

The LSP method is based on condensing the input material by exposure to strong vacuum in the melt phase. This method is unique and considerably more effective than conventional processes.

Effectively removing the contaminants out of the desired end product requires the largest possible material surface area and high mobility of the individual molecules. The **P:REACT** fulfills both requirements in a single process.

Once in the melt phase, the material enters the vertical section of the reactor and formed into strands, thus creating an ideal surface area to volume ratio. The liquid state of matter enables

the contamination molecules to migrate to the surface quickly, where they are removed in the vacuum system and collected in a waste container.

COMPLETE CONTROL OVER IV VALUES

The PET is subsequently collected and homogenized in the horizontal reactor section. The condensation process is initiated immediately upon strand formation and continues until the PET melt exits the reactor.

By varying the internal process parameters the output *iV* can be controlled and maintained within a narrow range.

No compromises, clean

FDA AND EFSA CONFIRM: VALUES FAR BELOW THE LIMITS

In addition to the high mobility of the molecules in the liquid phase, the enormous surface area exposure of the melt strands is another factor in effective cleaning. This means that the quality of the decontaminated material far exceeds the acceptable limits specified by EFSA and FDA.

The system has been approved for **100% food contact!**

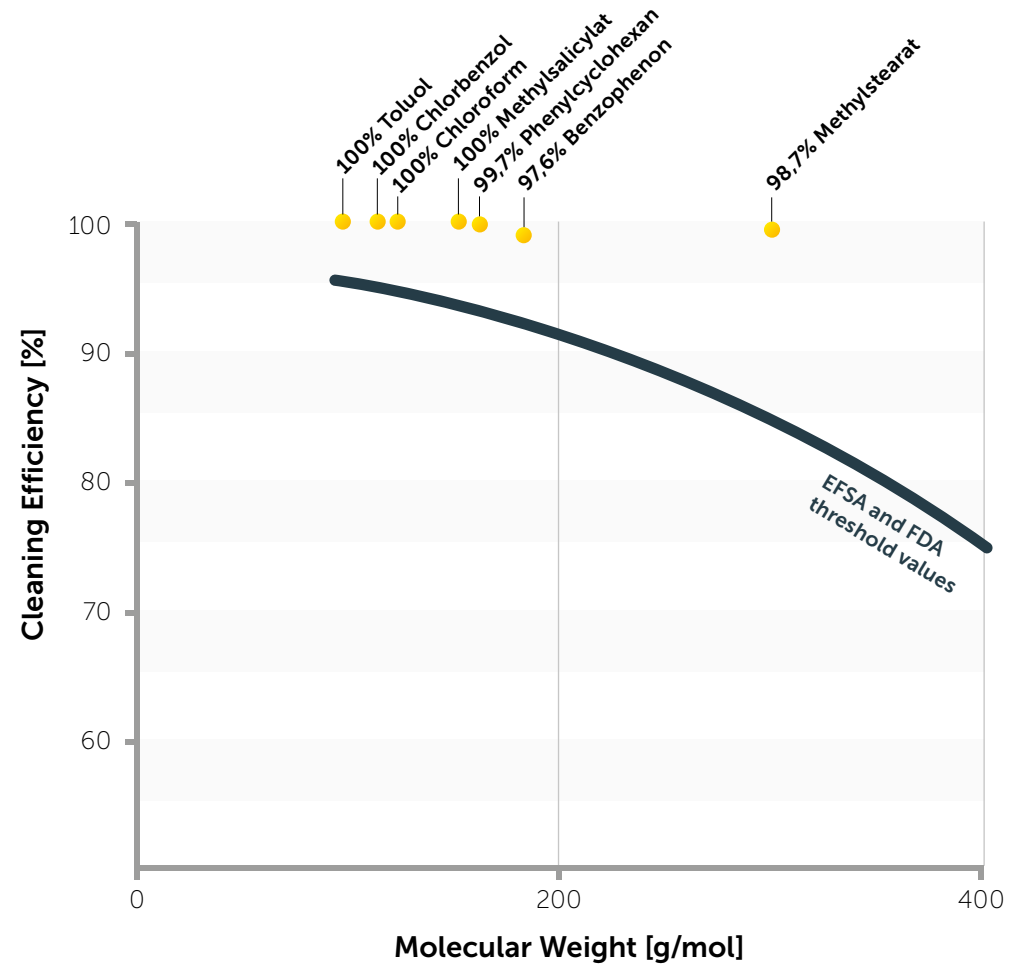

Reliable decontamination performance, certified for 100% food contact.

Dust-free from the start

SAFETY THROUGH CLEANLINESS

Bottle flake is the input material in a significant portion of conventional recycling processes. An inherent problem with processing bottle flake is dust, which can cause a wide variety of issues in downstream processes.

LSP IS DUST-FREE

Because the reaction occurs in the melt phase, the LSP process is completely dust-free.



Smooth and stable process
without dust: **P:REACT**
operates in the liquid phase

Conscious of problems, **focused on solutions**

COMPLETE DECONTAMINATION DESPITE POLYOLEFINS AND CO-POLYESTERS

In many packaging film applications, PET is co-extruded with PET-G or polyolefins. Due to the low glass transition temperature of these materials, clumping can occur with conventional recycling methods, substantially disrupting the decontamination process.

In the LSP process, all components are melted in and condensed together with the PET input material, resulting in a completely homogenized output. Therefore, such mixed polymer materials previously considered as problematic, can now be completely recyclable.



Co-polyester and polyolefin
contaminants **do not interfere**
with decontamination

Unbeatable, fast

EXTREMELY FAST IMPROVEMENT OF MATERIAL CHARACTERISTICS

Due to the incredibly fast reaction times in the decontamination stage, the **P:REACT** makes it possible to process materials with minimal iV input values.

Depending on the application, an iV build-up of approximately 0.1 dl/g per minute can be expected. Conventional methods take hours to achieve this. In total, an iV build-up of more than 30% can be achieved across the **P:REACT**, based on output value measurements.



Maximal flexibility for the iV input values thanks to **very high iV increase rates.**

Reliable, stable

ELIMINATING FLUCTUATION

Even with large variations in input iV the LSP process delivers a uniform output with highly stable iV value.



P:REACT compensates for iV fluctuations of the input material—**the iV values of the end products can be controlled.**

"The LSP method allows us to build up a very high iV value with remarkable speed—even when processing materials with materials that have low iV input values. The desired iV value is also largely controllable with minimal fluctuations!"

Mathias Strasser / Area Sales Manager



Cost-effective, consistent quality

MULTIPLE MATERIAL STREAMS FOR OPTIMIZING COSTS

The **P:REACT** gives its users maximum flexibility in terms of the mixing ratios and the composition of the input materials. Thanks to the high stability and full control over the iV values of the end product, the LSP process makes it possible to feed different material streams with iV values that do not match. The deciding advantage: Depending on the material availability and current price, this lets users optimize their production costs without compromising the consistently high quality of the end product.

INTEGRATABLE FUNCTIONS

Any upstream processes that may be required will also feature maximum flexibility. If pre-crushing is required for individual material streams, the shredding function is easy to integrate into the overall process. This function uses the tried-and-tested NGR shredder-feeder-extruder combination.



Multiple material streams
and variable mixing ratios for
maximum **optimization of
your production costs—while
keeping quality consistent.**

Continuous, productive

OPTIMAL CONDITIONS FOR DOWNSTREAM PRODUCTION

The LSP process stands out for its continuous long-run ability, as well as its highly stable process. The decontamination stage reliably maintains 100% continuous output flow, even during brief interruptions on the feeding side.

The output of the reactor is constant flow, constant pressure and constant iV , which provides the optimal conditions for connecting directly to a film, fiber or strapping system or to preform production. This streamlined and incredibly efficient transition into downstream production means that you cut down on costs while substantially improving your carbon footprint.



High efficiency: The stable reactor output makes it possible to directly connect to downstream production processes.

Energy-saving, efficient

RE-USE OF THE ENERGY

The energy that has already been expended for melting the input material is simply maintained throughout the reaction process. High-quality insulation minimizes energy losses.

SHORT RESIDENCE TIME

Due to the extremely low residence time inside the reactor, **P:REACT** is very energy-efficient compared to conventional processes, despite the higher temperature.

REDUCED CO₂ FOOTPRINT

The high process stability of **P:REACT** allows the melt to be transferred directly to downstream production. Systems of this type eliminate the need for pelletizing and remelting. Overall process flow and carbon footprint are considerably improved.

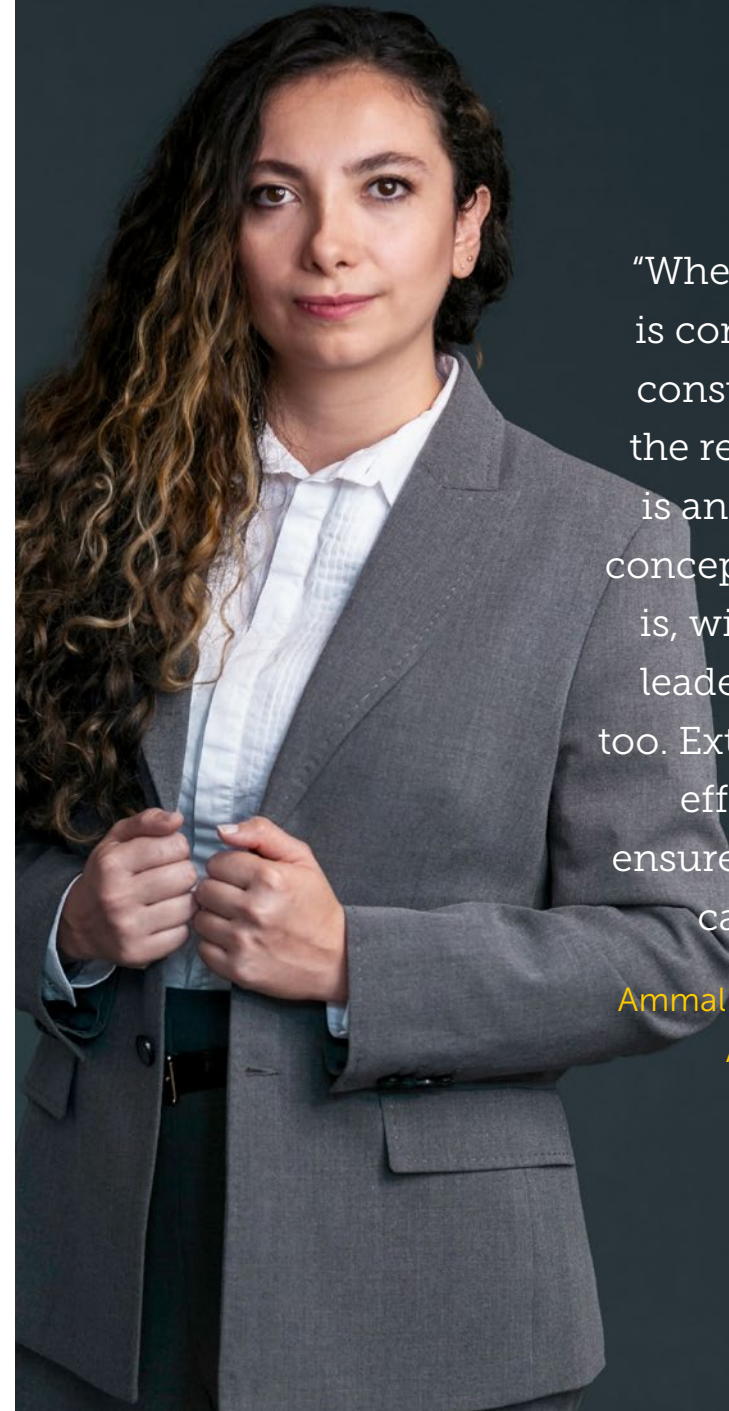

"Where sustainability is concerned, energy consumption during the recycling process is another important concept. The P:REACT is, without a doubt, a leader in this respect too. Extremely energy-efficient operation ensures a much better carbon footprint!"

Ammal de Paul Bulhosen /
Area Sales Manager

Energy consumption

Fiber production case study



0.28 kWh/kg

0.12 kWh/kg

High performance, compact installation

MINIMAL SPACE REQUIREMENTS

The **P:REACT** stands out for its efficient layout and as its low structure. LSP applications are mostly integrated into production lines in existing plants. This approach does not require specialized construction or high-bays for accommodating large silos, for instance.

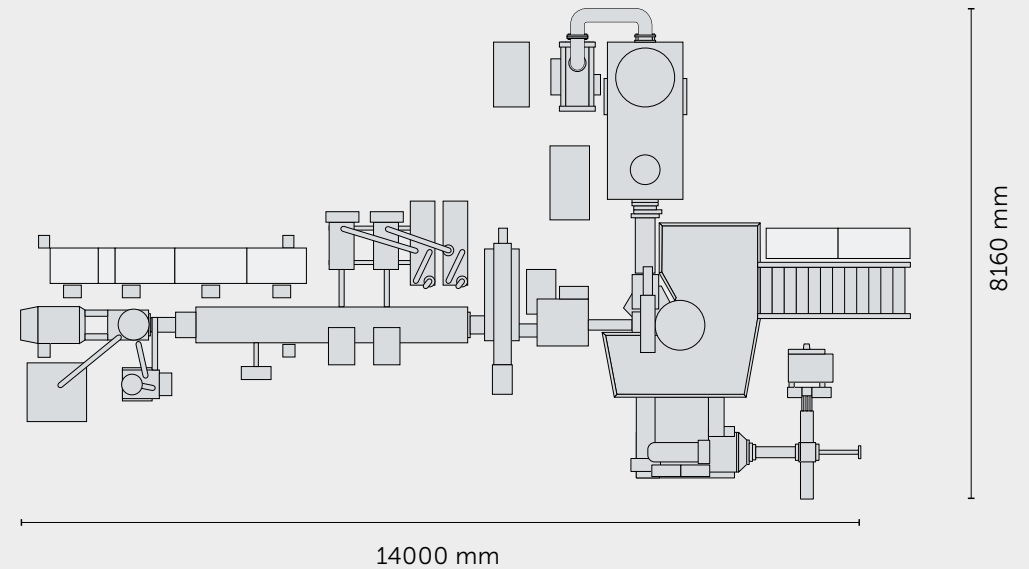
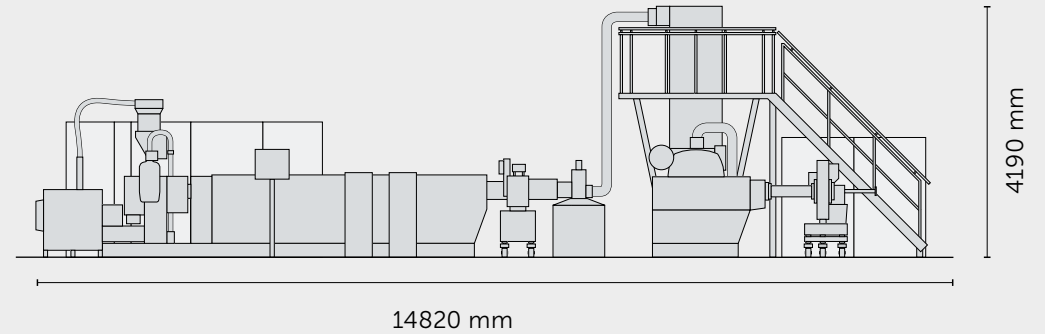

Constant, flexible

THE FLEXIBILITY OF A CONTINUOUS PROCESS

The continuous LSP process makes it possible to adapt substantial process changes during ongoing operation. Raising or lowering the output iV , for example, takes effect after just a few minutes. Unlike batch processes, changes such as color switching can also be implemented without interrupting operation. Such process changes normally do not require that the reactor be shut down for a lengthy changeover.



Significant operating parameters changes can be done without interrupting the continuous process.

Automatic, **correct**

CENTRAL MANAGEMENT

A central touchscreen gives you straightforward, user-friendly control over the **P:REACT**. Intuitive menu guidance and self-explanatory icons make operation far easier.

The central control unit is also used for recipe management. As a result, tracking and reproducibility are absolutely ensured in the event of changing input materials and fluctuations of the specific mixing ratios.



Highly developed
P:REACT technology, even
during operation: **100%**
reproducibility for your
recipes and intuitive control.

Application examples PET materials



Fibers
Fiber production



Bottle flakes
after plastic washing
system

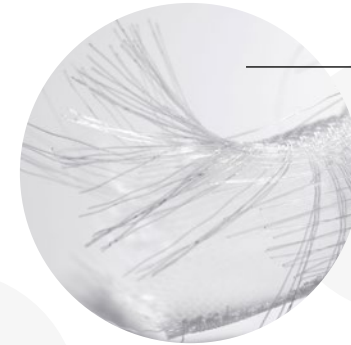

Textiles,
Production waste



Start-up lumps

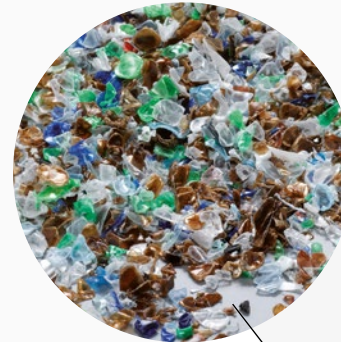

Bottle flakes
mixed after plastic
washing system

Deep drawing for
thermo-molded
parts

Fleece
Production waste



Preforms,
Injection molding

Punch scrap
deep drawing



Production of **PET pellets**

HIGH-QUALITY END PRODUCT

The effective decontamination and the precisely controllable iV buildup turn the **P:REACT** into the ideal technology for the production of rPET pellets, too.

In addition to rPET pellet production, it is also possible to connect the system directly to downstream production hassle-free.





"Our company is small enough to enable us to act dynamically on an international level. This enables us to guarantee the availability of spare parts around the world."

Mara Mathä / After Sales Service

Perfect satisfaction included



CONTINUOUSLY AVAILABLE SPARE PARTS PACKAGES

For the shortest standstill times and smooth start-up without delay, NGR offers its customers spare part and commissioning packages. These are adapted to the individual requirement and guarantee 100% reliability.



FASTEST SPARE PARTS SUPPLY

Spare components can be requested conveniently by phone, email or the NGR spare parts web shop. Stocked spare parts are delivered within 24 hours in Europe.

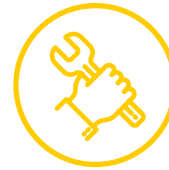

HIGHEST LEVEL OF PROFESSIONAL MAINTENANCE & TRAINING

The most professionally trained technicians are standing by around the world, ready to maintain and repair the systems. In addition, each maintenance appointment also includes follow-up training for the operators—to ensure maximum performance.



IMMEDIATE REPAIR SERVICE

In case of a sudden malfunction, a on-call service is available six days a week (Mon–Sat) for rapid-response repairs. These are either carried out by remote access or by local service partners with short turnaround times.



RETROFIT & USED MACHINES

NGR works pro-actively towards improving cost-effectiveness and extending service life: For example, after certain time frames, we recommend that individual components be replaced or software updated for better performance.

Specifi cations



	min kg/h	máx kg/h	min lbs/h	máx lbs/h
P:REACT 600	300	700	660	1540
P:REACT 1200	600	1400	1320	3080
P:REACT 2000	1400	2200	3080	4840

In addition, NGR provides all equipment for pellet transport, such as fans, pipes, cyclones, etc.

Contact us with **your challenge**

YOUR PLASTIC WASTE IS THE RAW MATERIAL OF TOMORROW.

In our recycling test centers, we can prove the NGR reprocessing performance on your own scrap materials. We look forward to the opportunity to prove it to you in person.



**WE DON'T
PRINT.
DO YOU?**

Working
for a better
future

**Next Generation
Recyclingmaschinen GmbH**

HQ, Production & Customer
Care Center Europe



+43 7233 70 107-0



info@ngr-world.com



Gewerbepark 22
4101 Feldkirchen
Österreich



[Follow us on LinkedIn](#)



[Watch on YouTube](#)